

TECHNICAL DATA SHEET



ALTERNATOR E2W13S/2 300DC-K

DC welder with brushes

E2W13S/2 300DC-K

COMMON DATA

Rated Power at 50Hz	kVA	10
Rated Power at 60Hz	kVA	12
Rated Power Factor		0,8
Nominal Temperature	°C	40
Control System		self-excited
Execution		with brushes
Insulation Class		H
Protection		IP21
Maximum Over speed	rpm	4500
Overload		110% of rated power for one hour in a cycle of 6 hours
Air Flow Requirement	m ³ /min	9,4 at 50Hz 11,2 at 60Hz
R.F.I. Suppression		Standard EN55011

REGULATION DATA

Regulation	Compound
Voltage Regulation	±4%

WINDING DATA

Rotor Winding	with damping cage
Number of Leads of Stator	6
Stator Winding Resistance	Ω 1,05 at 20°C
Rotor Winding Resistance	Ω 10,26 at 20°C

STANDARD

References	EN60034-1 ISO8528-3 EN55011
------------	-----------------------------

E2W13S/2 300DC-K

ELECTRICAL DATA

No load voltage	V _{AC}	80
Welding voltage	V _{AC}	20-32
Regulation range	A _{AC}	35-300
Max. current at 35%	A _{AC}	300
Max. current at 60%	A _{AC}	240
Max. current at 100%	A _{AC}	185
Stator Winding Resistance	Ω	0,023 at 20°C
Electrodes type		basic; cellulosic; inox, rutile
Electrodes diameter	mm	1 - 5(6)

MECHANICAL DATA

Bearing non drive end		6305-2Z-C3	
Bearing drive end (B3/B14 form)		6208-2Z-C3	
Weight of generator	in B2	kg	87
	in B3/B14	kg	82,9
	in B3/B9	kg	80

MOMENT OF INERZIA

B3/B9	kg·m ²	0,058
SAE 7½	kg·m ²	0,052
SAE 8	kg·m ²	\
SAE 10	kg·m ²	\
SAE 11½	kg·m ²	\
SAE 14	kg·m ²	\
SAE 18	kg·m ²	\
B3/B14	kg·m ²	0,058

E2W13S/2 300DC-K

DERATING CURVES

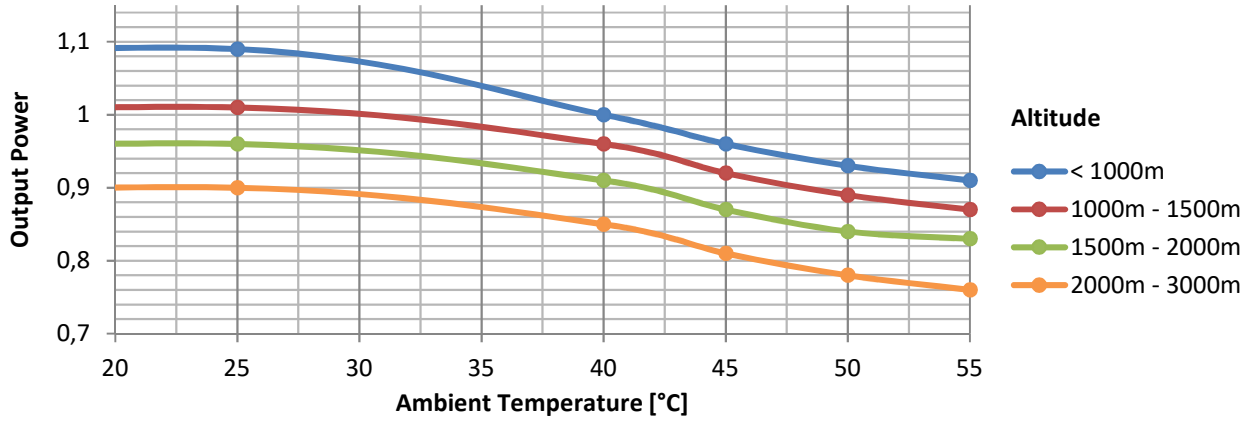

WIRING DIAGRAM

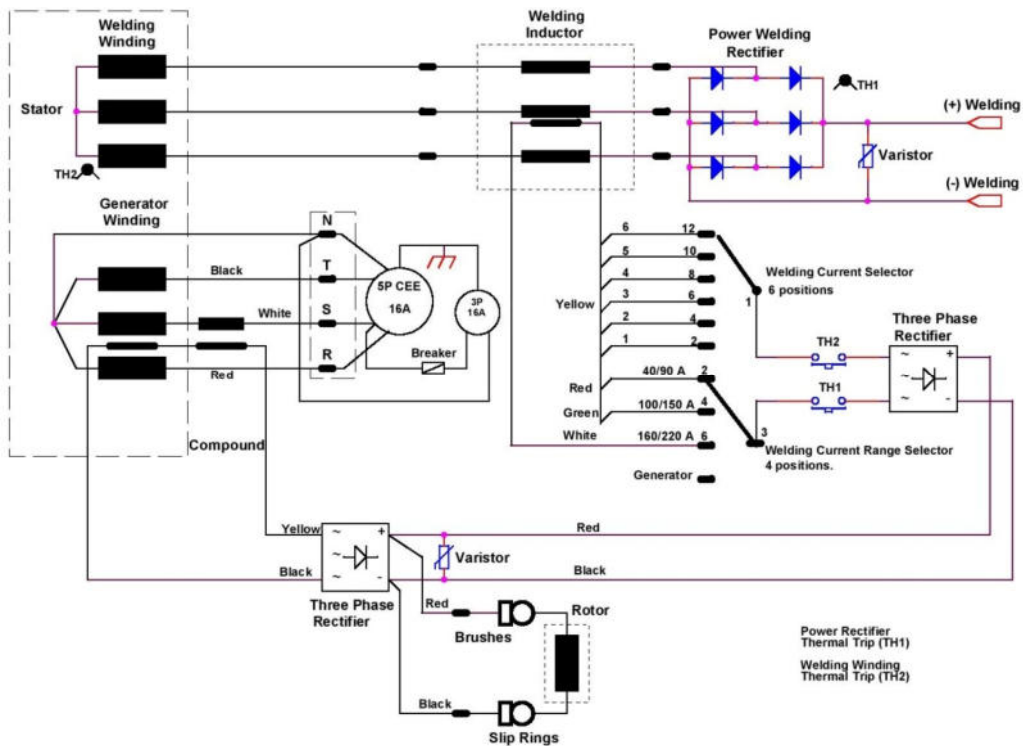

E2W13S/2 300DC-K

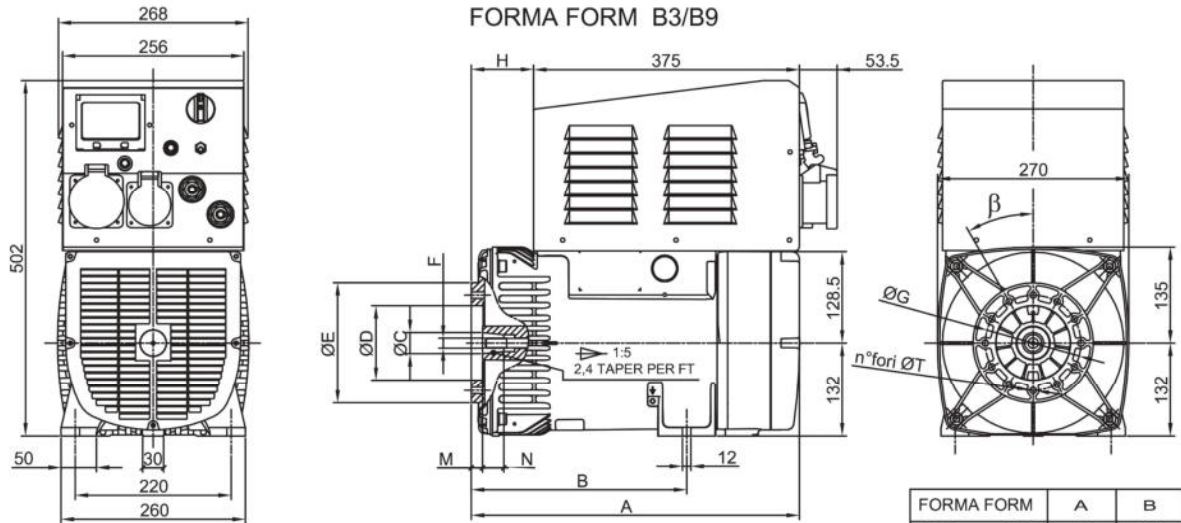

FORMA FORM	ØC	ØD	ØE	F	ØG	H	M	N	n° fori holes No.	ØT	β
cono Ø30	Ø30	Ø105	Ø170	M14x1.5	Ø135	88	16	30	12	Ø9	30°
cono Ø38	Ø38	Ø125	Ø185	M18x1.5	Ø150	79	5	30	4	Ø11	β/2 45°

FORMA FORM	A	B
B3B9 cono Ø30	463	304
B3B9 c.Ø38-J609b	454	295
B3/B14	448	312
MD35 - LOMB. STD	496	337

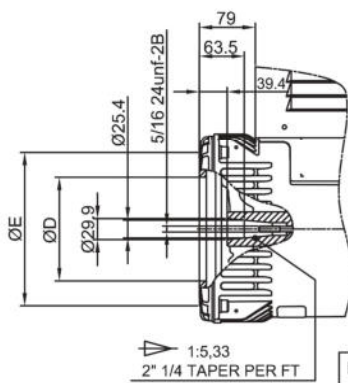

FORMA FORM J609b

FORMA FORM	ØD	ØE	ØG
J609b	Ø146	Ø192	Ø165
	Ø163.6	Ø216	Ø196.85
	Ø177.8		

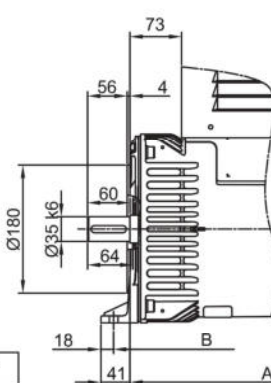

FORMA FORM SAE

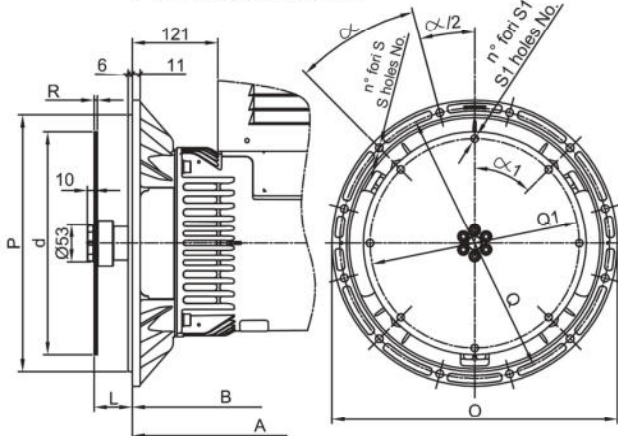

SAE N.	FLANGE - FLANGES				
	O	P	Q	n. fori holes No.	S
5	356	314.3	333.4	8	45°
4	403	362	381	12	30
3	451	409.6	428.6	12	30

FORMA FORM LOMBARDINI STD

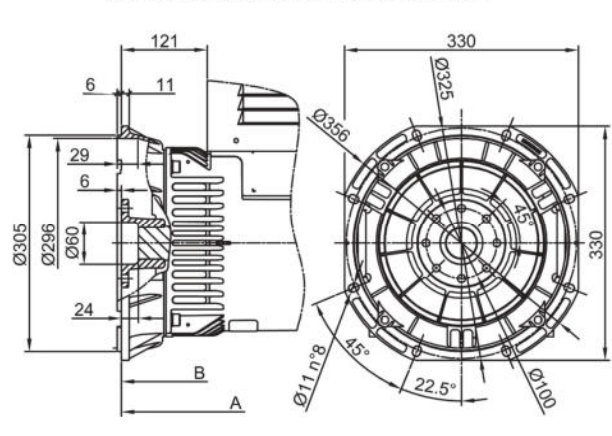

SAE N.	GIUNTI A DISCO - COUPLING DISCS						
	L	d	Q1	n. fori holes No.	S1	α1	R
6 1/2	30.2	215.9	200	6	9	60°	3
7 1/2	30.2	241.3	222.25	8	9	45°	
8	62	263.52	244.47	6	10.5	60	4.5
10	53.8	314.32	295.27	8	10.5	45°	
11 1/2	39.6	352.42	333.37	8	10.5	45°	